

HEADER BLOCK ANCHOR

- ★ For use with concrete header block foundations
- ★ Eliminates the drilling of bottom plates
- ★ No need to use Anchor Bolts
- ★ Use at 600mm crs. max.
- ★ Complies with Clause 7.5.12.2 NZS 3604:2011

NZ Pat. Appln. 264928,
270081, 272507

Fig. 1

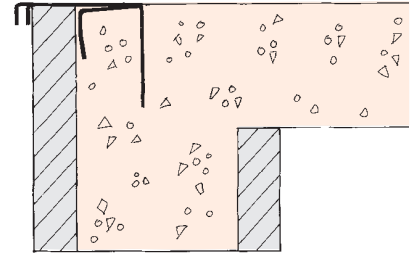
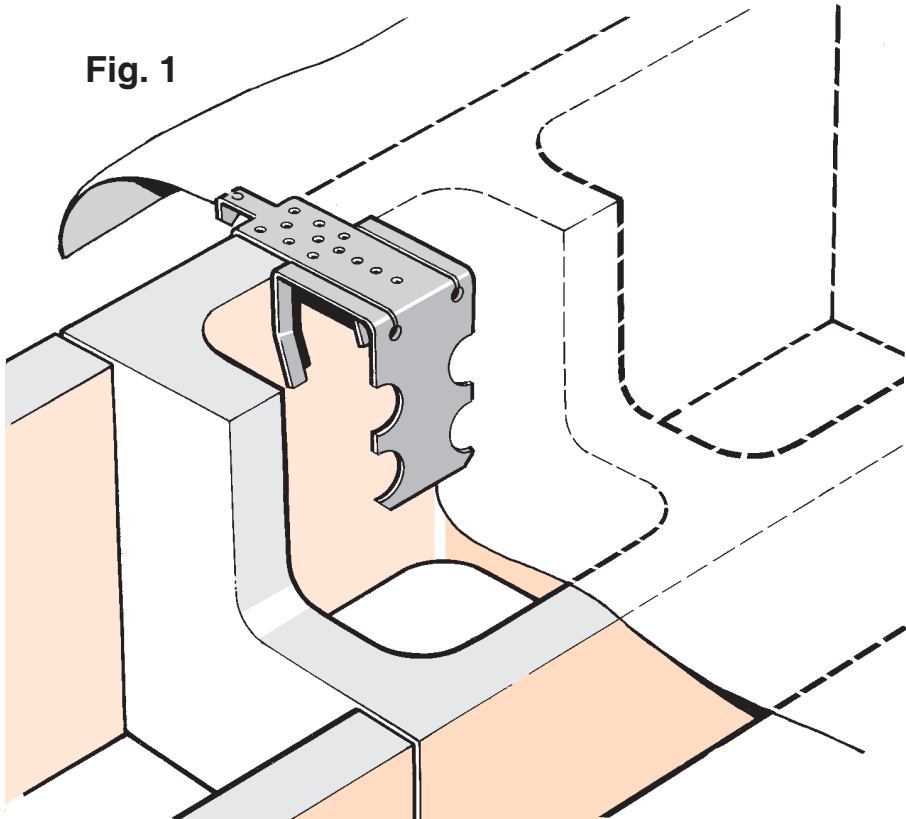

1. Header Block Anchors shall be fixed at 600mm centres max. to the upstand edge of the header blocks, over a continuous vapour barrier (Fig.1). Each Header Block Anchor is positioned on to the blockwork prior to concrete pour and shall be left undisturbed until the concrete has hardened sufficiently to locate and position the timber frames.

2. Prior to placing timber frames, the centre flap of the Header Block Anchor must be lifted up from the slab and folded back to allow the wall frame bottom plate to be positioned in place. (Fig. 2)

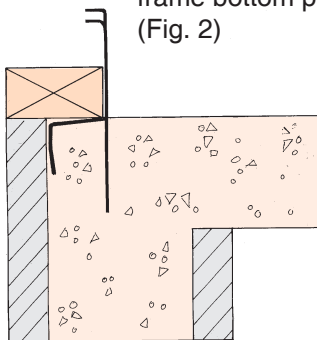
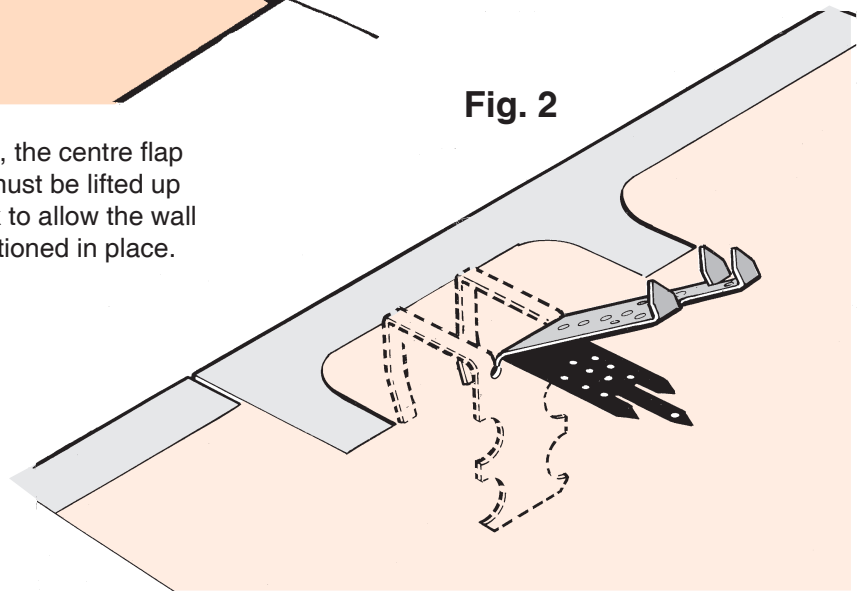

Fig. 2



**Available from leading Builders Supply Merchants
throughout New Zealand**

3. One LUMBERLOK Product Nail 30mm x 3.15 dia. should then be driven into the inside face of the bottom plate and at least four additional nails applied through the remaining flange, which is either wrapped over the top of the bottom plate or fixed to the face of a stud or block should the Header Block Anchor not line up with the stud. (Fig. 3).

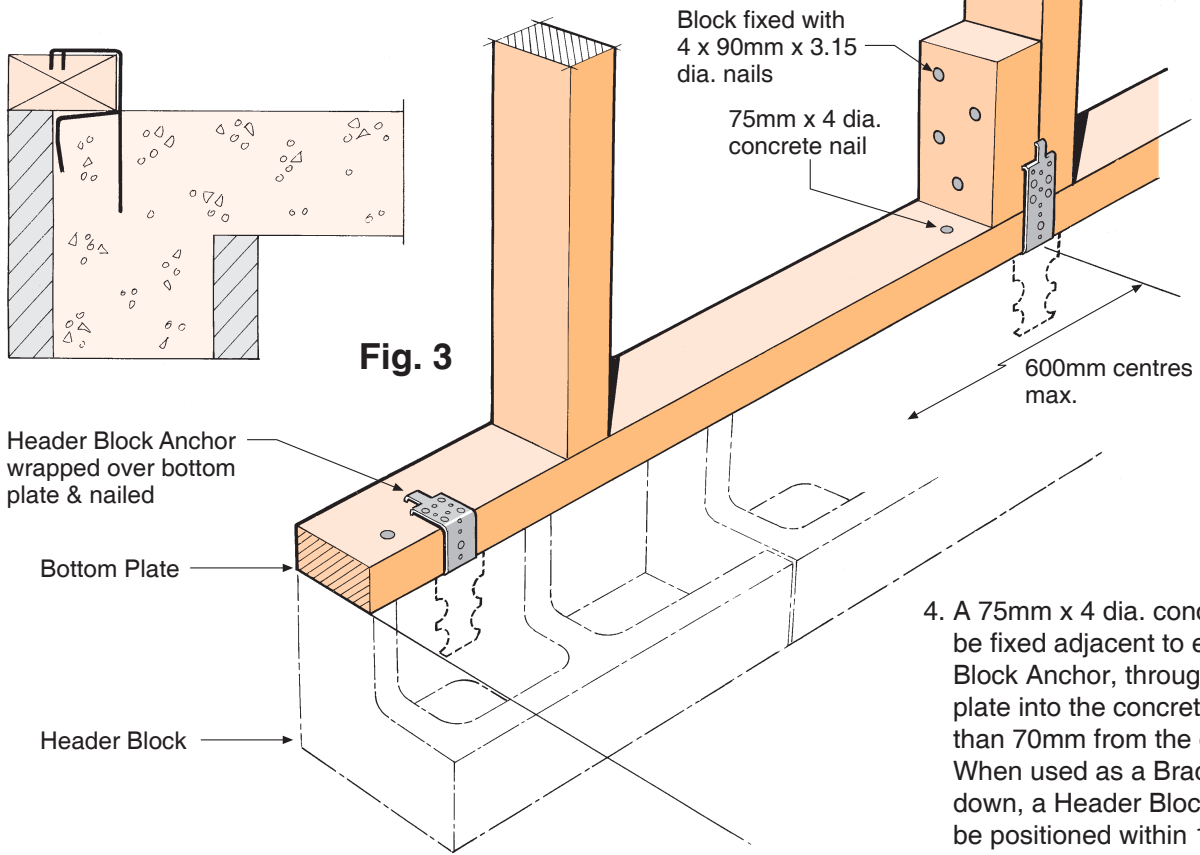

Fig. 3

4. A 75mm x 4 dia. concrete nail must be fixed adjacent to each Header Block Anchor, through the bottom plate into the concrete, at not less than 70mm from the concrete edge. When used as a Bracing Wall hold-down, a Header Block Anchor must be positioned within 150mm from the end of that wall. Bracing wall must not exceed 70 BU/m.

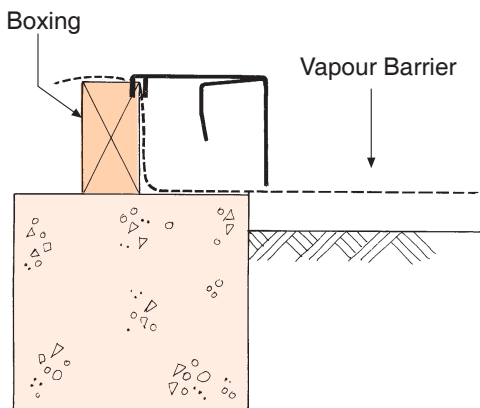
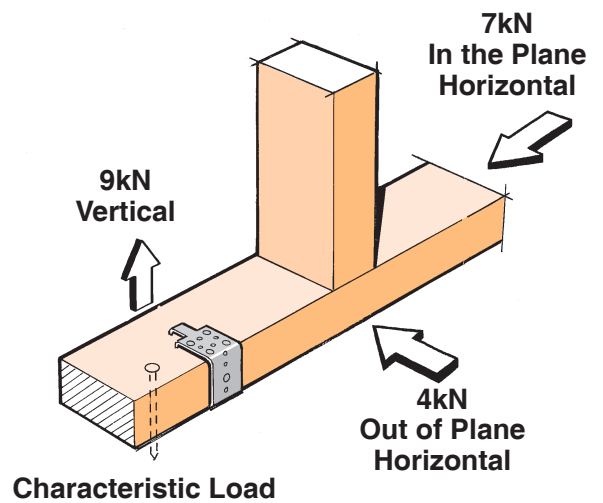

Fig. 4

5. Header Block Anchors have also been designed to enable them to be used with timber boxing, as opposed to using concrete header blocks. (Fig. 4). Note however that the product is fixed around the **inside** face of the bottom plate.



Design Loads

Concrete compressive strength 17MPa min.

- Code:** HBA
- Material:** 1.15mm G250 Z275 Galvanised Steel
- Code:** SSHBA
- Material:** 0.9mm Stainless Steel 304-2B
- Packed:** 48 per Carton